

/ How to install the accessories correctly

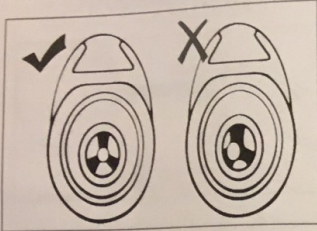

When installing the chuck, be sure to align the chuck port with the grinder port.

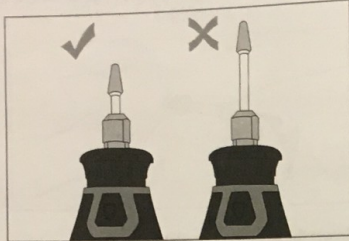

Make sure the most of shank inserting into the chuck.

Manufacture Info:

Company: SHENZEN XAWEE TECHNOLOGY CO.,LTD
Shen Zhen Shi Qian Hai Xin Wen Gong Mao You Xian Gong Si
Address: Room 201, BuildingA, NO.1 of Qianhai 1st Road the Former
Qianhai Shenzhen-Hongkong Cooperation Zone
Shenzhen Guangdong 518054 China

Tel: +86 150 1259 3927

E-mail: goxawee2017@hotmail.com(Europe)
info@xawee.com(USA)

EU|REP CET PRODUCT SERVICE LTD.

Address: Osterholzallee 144, 71636 Ludwigsburg Germany
E-mail: info.cetservice@gmail.com
Tel: +4971416432236

UK|REP CET PRODUCT SERVICE LTD.

Address: Chase Business Centre, 39-41 Chase Side, Lon don N14 5BP
United Kingdom
E-mail: info.cetservice@gmail.com
Tel: +447419325266

Made in China

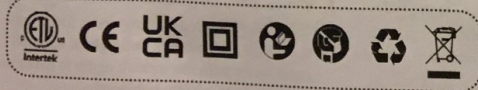

GOXAWEE®

ROTARY TOOL



User Manual





 For your own safety, please read the User Manual before using the tools.

Safety and Note

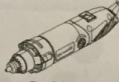

1. Before using the tool, please use personal protective equipment, always wear goggles and overalls to avoid accidents.
2. Before the grinder is energized, please make sure the switch is OFF.
3. When installing or replacing accessories, make sure to unplug before starting.
4. Before the operation, the rotary tool accessories should be inspected carefully, and prohibited to use the broken and cracked fixtures.
5. When installing the accessories, the chuck of the electric grinder / flexible shaft must be tightened with the wrench.
6. Before starting work, please make sure that the attachment and accessories are fastened, then test the electric grinder without load. If there is no abnormality, you can continue to operate.
7. During use, please pay attention to the pressure of the grinder to avoid excessive force.
8. When using cutting discs or other accessories, make sure that person stays away from the tangential direction of the cutting disc in order to avoid injury.
9. For North American countries, this grinder only supports 100-120V voltage; For European countries, this grinder only supports 220-240V voltage.

User manual fits for the models as below:

Model	 G1337C G5045	 G1338 G1338-388-1332	 G1337 G4007	 G4115
Voltage	220 V ~ (EU) 120 V ~ (US)	220 V ~ (EU) 120 V ~ (US)	220 V ~ (EU) 120 V ~ (US)	220 V ~ (EU) 120 V ~ (US)
Frequency	50 Hz (EU) 60 Hz (US)	50 Hz (EU) 60 Hz (US)	50 Hz (EU) 60 Hz (US)	50 Hz (EU) 60 Hz (US)
Rated Input Power	240 W	130 W	130 W	135 W
Rate Speed	8000-32000 RPM	8000-30000 RPM	8000-30000 RPM	0-35000 RPM
Collet Capacity	0.5-6.0 mm	3.2 mm	3.2 mm	3.2 mm

/ G1337C & G5045 Structure

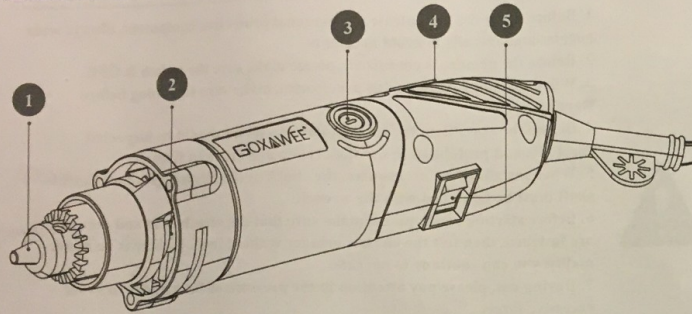

- | | |
|--|--|
| 1. Chuck: 0.5-6.0 mm | 4. Speed Switch: Variable speed |
| 2. Heat Vent: Rapid heat dissipation | 5. On/off Switch: Turn on / turn off the grinder |
| 3. Carbon Brush Mouth: Change the carbon brush | |

/ G1338 & G1338-388-1332 Structure

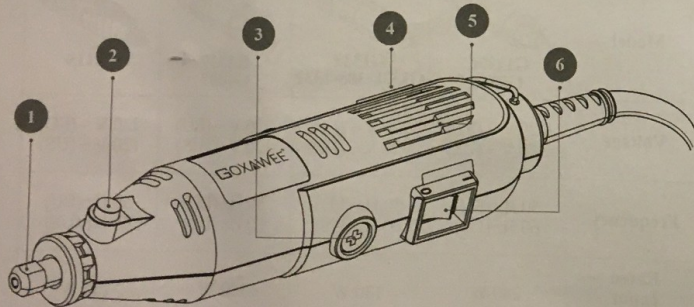

- | | |
|--|--|
| 1. Chuck: 3.2mm | 4. Speed Switch: Variable speed |
| 2. Collet Nut: Lock the chuck | 5. Heat Vent: Rapid heat dissipation |
| 3. Carbon Brush Mouth: Change the carbon brush | 6. On/off Switch: Turn on / turn off the grinder |

G1337 & G4007 Structure

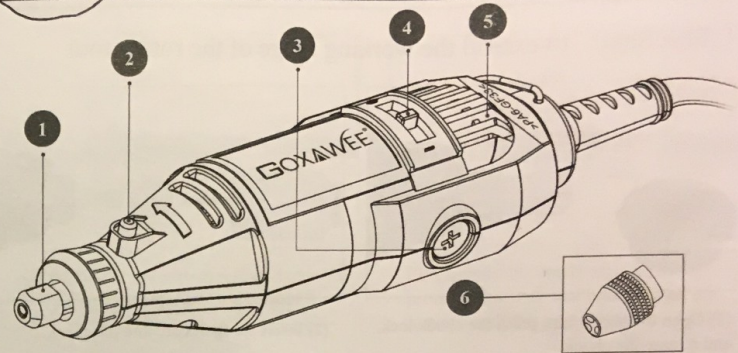

- | | |
|--|--|
| 1. Chuck: 3.2mm | 4. Speed Switch: Variable speed |
| 2. Collet Nut: Lock the chuck | 5. Heat Vent: Rapid heat dissipation |
| 3. Carbon Brush Mouth: Change the carbon brush | 6. Keyless chuck: Accept 0.5-3.2mm shank |

/ G4115 Structure

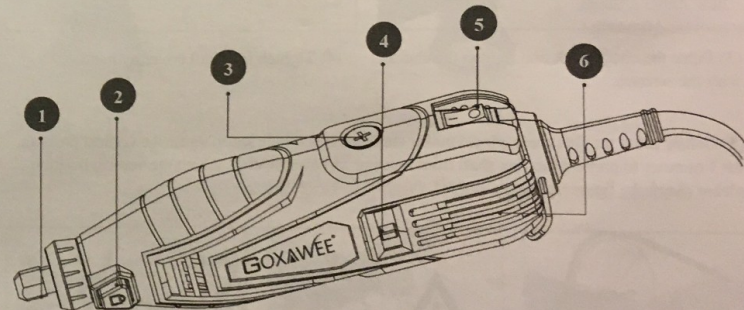

- | | |
|--|--|
| 1. Chuck: 3.2mm | 4. Speed Switch: Variable speed |
| 2. Collet Nut: Lock the chuck | 5. On/off Switch: Turn on / turn off the grinder |
| 3. Carbon Brush Mouth: Change the carbon brush | 6. Heat Vent: Rapid heat dissipation |

/ Optional Attachments and the Installation

1. Flex Shaft - to extend the working range of the rotary tool

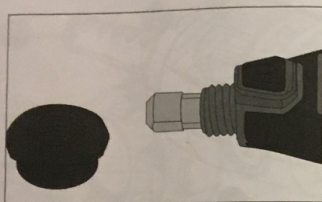

(1) Open the plastic nut, press the chuck lock, and release the chuck.

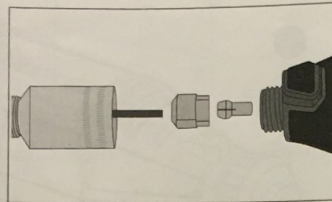

(2) Insert the shaft core into the chuck.

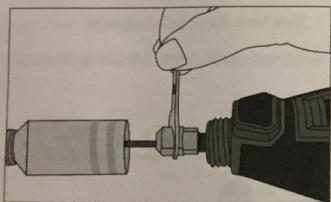

(3) Press the chuck lock and tighten the chuck with the wrench.

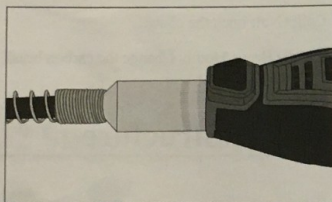

(4) Tighten the shaft cover by hand.

(5) Before using the flex shaft, please make sure it runs at a high speed under the vertical position for 1 minute to prevent the flex shaft from twisting and over heating. About the vertical position, please check the figure below.

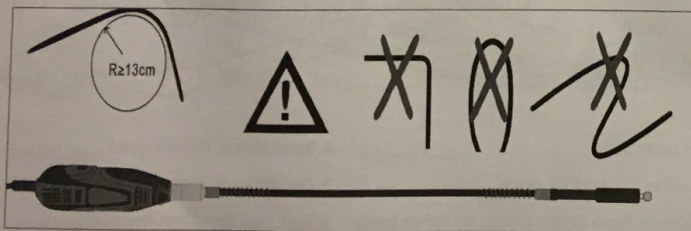

/ Optional Attachments and the Installation

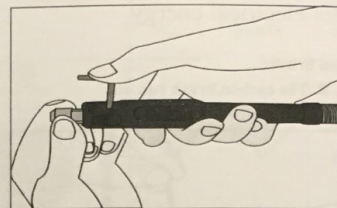

(6) Use the "L" spanner inserting it into the hole at the head of the shaft then presses it, open the collet nut.

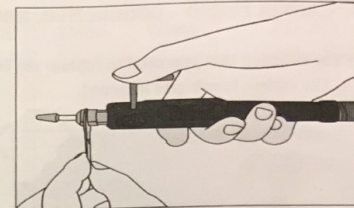

(7) Place the accessory into the collet, press "L" spanner and tighten collet nut in place with the small wrench.

2. Drill Locator - control the depth of drilling

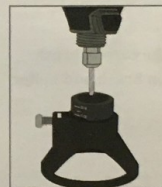

(1) Unscrew the plastic nut and install the drill bit.

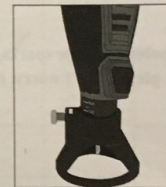

(2) Tighten the drill locator on the head of the grinder, adjust the scale according to the drilling depth, and tighten the screws by hand.

3. Cover Shield - prevent getting hurt from sparks and debris

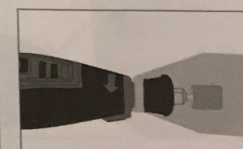
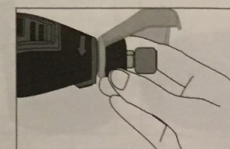
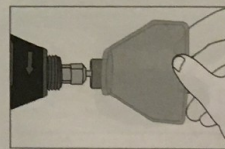

(1) Unscrew plastic, attach the cover shield to the grinder head and tighten the nut.
 (2) Install the accessories, tighten the chuck, check it and start working.

/ Optional Attachments and the Installation

4. Carbon Brush - conductive, transfer electrical energy

• The situation that you need to replace the carbon brush:

A. The carbon brush gets loosened.

B. The carbon brush run out.

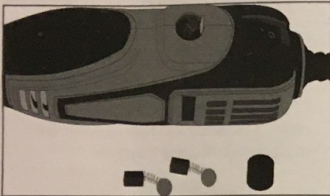

(1) Insert the end of the wrench into the carbon brush port and unscrew it to remove the damaged carbon brush.

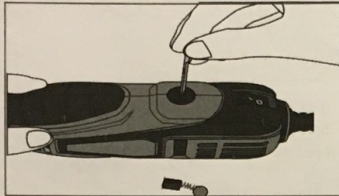

(2) Insert the new carbon brush into the carbon brush port correctly and cover the port with the wrench.

• **Note:** If the ventilation holes generate sparks when you just replaced the carbon brush and turn on the machine, please don't worry, it's because the new carbon brush and motor getting contacts.

5. Polishing Compound - enhance the polishing effect

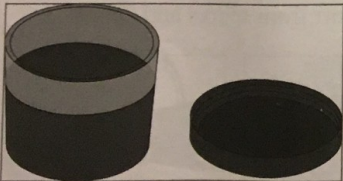

(1) Install the felt wheel to the chuck and tighten, then open the polishing paste.

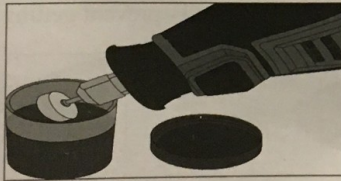



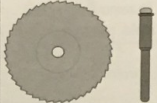
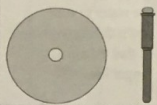
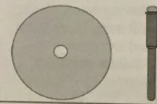
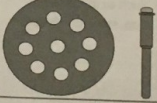
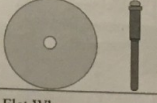
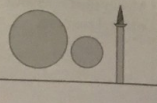

(2) Dip the felt wheel into the polishing paste and rotate it at a low speed, then apply the felt wheel to the polishing project.

/ Optional Accessories - 1

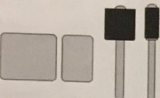
	Wood	Plastic	Metal	Stone	Glass	Pro Tip
Mini HSS Cutting Disc 25 x 0.4mm 	✓	✓	✗	✗	✗	Please make sure that the saw blade gear and the grinder rotate in the same direction.
Cut Off Wheel 32 x 1.3mm 	✗	✗	✓	✗	✗	Not suitable for alloy metal with too high hardness.
Resin Cutting Disc 24 x 0.8mm 	✗	✗	✓	✗	✗	Not suitable for alloy metal with too high hardness.
Diamond Cutting Disc 22 x 0.7mm 	✗	✗	✗	✓	✓	Due to the high temperature, please use water to cool down during working so that extend a longer life.
Sanding Paper Disc 20 x 0.4mm 	✓	✗	✓	✓	✓	To polish, grind and remove stains. Recommended to install and use 3 discs or more for better effect.
Flet Wheel 25 x 7mm 13.5 x 6mm 	✓	✗	✓	✓	✓	For polishing plastics, metals, jewellery and models, etc. (Can be used with polishing paste).

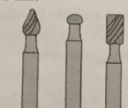
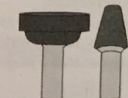
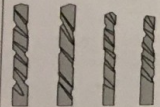
/ Optional Accessories - 2

	Wood	Plastic	Metal	Stone	Glass	Pro Tip
Sanding Drum 15 x 12.6mm 13.5 x 9mm 	✓	✓	✓	✓	✓	To remove stains and mold, paint, etc.
Diamond Burr Bit 3 mm 	✓	✓	✓	✓	✓	Due to the high temperature, please use water to cool down during working so that extend a longer life.
Rotary Burr 3 mm 	✓	✓	✗	✓	✗	Not suitable for alloy metal with too high hardness, suitable for shaving wood, plastic, soft metal (aluminum) and soft stone with hardness below 3.5 degrees.
Abrasive Stone 3 mm 	✓	✓	✓	✗	✓	Such as aluminum, iron, steel, copper, etc.
HSS Twist Drill 	✓	✓	✓	✗	✗	Generally used with drill locator. For soft metals (5mm aluminum, 3mm high carbon steel).
Wire Brush 3.2 mm 	✓	✓	✓	✗	✗	For cleaning, deburring and surface treatment. Mainly used to remove rust and corrosion.

/ How to install the accessories correctly

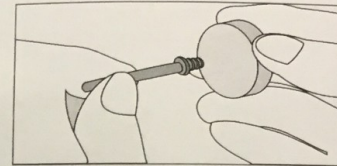

Insert the mandrel into the felt wheel.

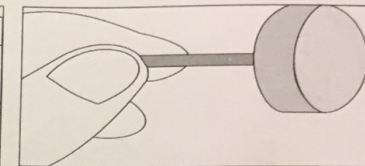

Tighten the mandrel by hand wholly tightened.

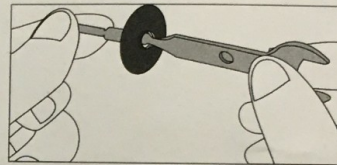

Unscrew the mandrel screws and install 3 or more discs of sandpaper.

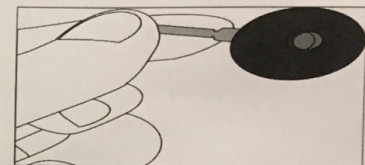

Insert the installed sandpaper device into the chuck and tighten with the wrench. Then tighten the screws on the mandrel head with the wrench.

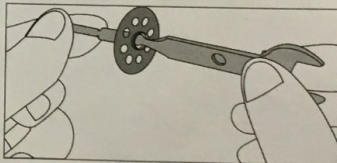

Unscrew the head screw of the mandrel and attach the cutting disc.

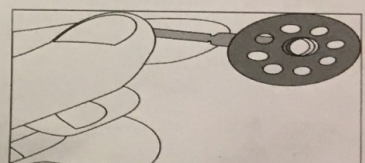

Install the mounted cutting disc in the chuck, and fasten the chuck and the cutting disc screw with the wrench.

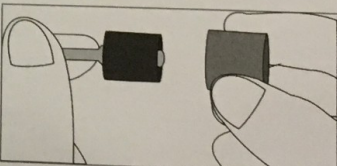

Loosen the screw of the mandrel, install the sanding drum, and tighten the screw with the wrench.

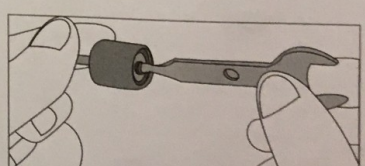

Install the installed sanding drum fitting into the chuck and fasten it, and tighten mandrel head screw with the wrench again to make the sanding drum wholly tightened.